

MARS PRO 1200

TECHNICAL DATA



HIGHLIGHTS

- 3-filter design for maximum protection when handling hazardous materials such as cytostatic, virustatic pharmaceuticals substances
- Compact Design enabling troublefree installation and relocation
- V-shaped table top
- Sloped front
- Excellent light distribution
- Electrical sliding front window
- Easy both side window cleaning

For more information please visit www.labogene.com

Details

Product family	MARS PRO
Model:	1200
Product type	Class II Biological Safety Cabinet according to EN 12469
Certificates	None
Compliance with	EN 12469, DIN 12980, EN 61010-1, EN 61000-6, EN11201
e-catalogue classification (UNSPSC code)	411035 Laminar flow cabinets or stations

General specifications	Unit		Note
Sound pressure level at factory settings	dB(A)	≤49	According to EN 11201
Sound pressure level in Eco-Save mode	dB(A)	≤38	Optional automatic mode shift available
Down flow, air velocity	m/s	0,28±0,01	Factory setting according to EN 12469
Inflow, air velocity	m/s	0,45	Factory setting according to EN 12469
Exhaust, air flow rate	m ³ /h	389	Factory setting according to EN 12469
Light illuminance (flourescent tube)	Lux	> 2000	Optionale dimmable version available
Front opening (height)	mm	200	Factory setting (adjustable between 0-300mm)
Number of table top segments		4	Customized layout and accessories upon request
Filter construction in accordance with EN 1822-1		3-filter system, HEPA, at least Class U17	
Table top and trough material		AISI 304 stainless steel	Optional AISI 316 stainless steel available
Table top max. total load	kg	100	
Side glass material		5 mm hardened glass w. 3 x ø22mm holes	Other hole options available
Front glass material		6 mm laminated safety glass	Optional antireflex coating available
Cabinet and backwall material/colour		Polyester coated steel/RAL 9016	Other RAL colours available upon request

Dimensions	Unit		Note
External dimensions with adjustable stand (Std. height) (DxWxH)	mm	797 x 1304 x 2033	See drawing for details. Can pass through a standard door opening size 0,9x2,1M.
Table top height with adjustable stand (Std. height)	mm	750 (Range 745-780)	2 additional stand heights available as options
External dimensions with elec. elevation stand (DxWxH)	mm	797 x 1414 X 2025-2325	Available as an option. Please take note of the changing width of the cabinet.
Table top height with elec. elevation stand	mm	750-1050	
Work chamber dimensions (DxWxH)	mm	480x1200x700	
Net weight	kg	308	
Shipping Volume	m ³	ca. 3,0	

MARS PRO 1200

TECHNICAL DATA

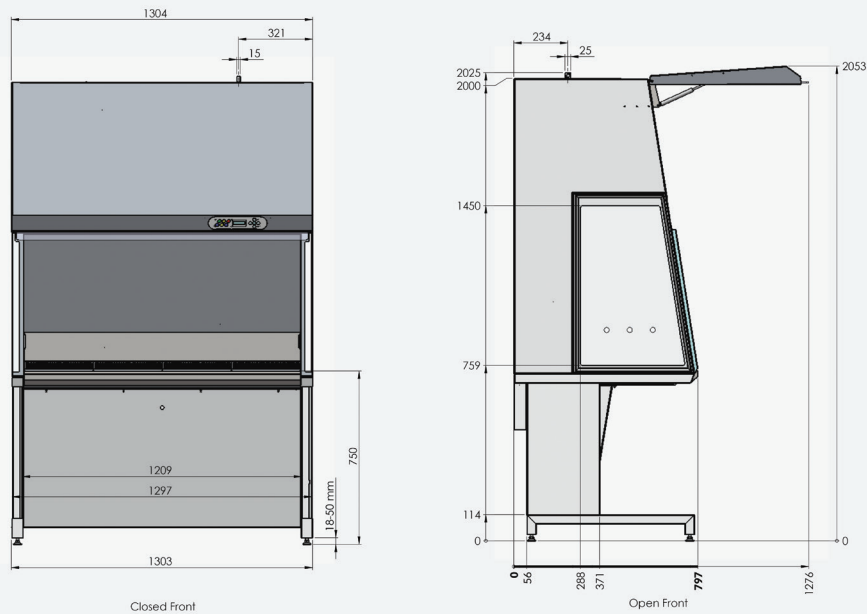

Electrical data	Unit		Note
Rated AC voltage/frequency	V/Hz	220-240/50-60	Other voltages available
Rated max. current (fuse)	A	10	
Power outlet(s) max. total current (fuse)	A	6,3	The sum of all power outlets
Type of power outlet socket, pair, left & right side		DK - type K (IP44)	Other types available. Select between 9 different regional types
Typical power consumption excl. power outlets	VA/Watt	154/142	With fluorescent dimmable light. At factory setting and normal operation
Typical power consumption excl. power outlets	VA/Watt	133/122	With LED dimmable light. At factory setting and normal operation
Typical power consumption in Eco-Save mode	VA/Watt	43/35	
Type of mains connection		3pin male type IEC320 C14	Top mounted, left or right side

Additional available options	Unit		Note
Electrical elevation - Worktop height range	mm	745-1050	
UV-C sterilisation		Easy and fast decontamination	
Extra Power outlets, pair, left & right side		Select between 9 different regional types	
Antiblow back valve straight Ø 200 mm			
Antiblow back valve side Ø 200 mm			
Programmable output module for external control purposes		4 sets of potential free contacts	
Hydrogen Peroxide Vapour (VHP) decontamination valves			

LaboGene ApS is Certified according to EN/ISO 9001 UKAS
 LaboGene ApS owns the copyright of this data sheet. Subject to technical changes.
 Illustrations and photos may contain options and modifications not supplied as standard.